



Software : by Martin J. King
e-mail MJKing57@aol.com

Copyright 2011 by Martin J. King. All Rights Reserved.

Configuration : Extended Range Driver w/ Bass Driver Mounted on an Open Baffle

Unit and Constant Definition

cycle := 2·π·rad

Hz := cycle·sec⁻¹

Air Density : ρ := 1.205·kg·m⁻³

Speed of Sound : c := 344·m·sec⁻¹



Part 1 : Thiele-Small Consistent Calculation

Detailed User Input (Edit This Section and Input the Parameters for the System to be Analyzed)

Power := 1·watt (Input Power) Applied Voltage Reference ---> R_{ref} := 8·Ω

Extended Range Driver Thiele / Small Parameters : Fostex FE-103E

f_d := 79.5·Hz V_{ad} := 6.90·liter

R_e := 7.45·Ω Q_{ed} := 0.40

L_{vc} := 0.0·mH Q_{md} := 2.87

Bl := 4.42· $\frac{\text{newton}}{\text{amp}}$ Q_{td} := $\left(\frac{1}{Q_{ed}} + \frac{1}{Q_{md}}\right)^{-1}$

S_d := π·4²·cm² Q_{td} = 0.351



Bass Driver Thiele / Small Parameters : Eminence Alpha 15" High Efficiency

f_d := 41·Hz V_{ad} := 260·liter

R_e := 5.88·Ω Q_{ed} := 1.53

L_{vc} := 0.84·mH Q_{md} := 7.23

Bl := 7.7· $\frac{\text{newton}}{\text{amp}}$ Q_{td} := $\left(\frac{1}{Q_{ed}} + \frac{1}{Q_{md}}\right)^{-1}$

S_d := 856.3·cm² Q_{td} = 1.263



Instructions :

1. If a Zobel is used, set L_{vc} equal to zero in driver inputs above. If no Zobel is used, enter a value for L_{vc} .
2. Select the crossover frequencies, orders, and types below.
3. Scroll down to the applicable crossover sections below and fill in the values of the circuit components.
 - a. The theoretical values are shown to the right of each schematic.
 - b. Theoretical values are calculated using only the driver's DC resistance, a textbook solution.
 - c. Enter the actual component values, these should correspond to available components.
 - d. Iterate the actual component values to optimize the crossover responses.
 - e. You can mix the crossover orders and types by using only half of each pair of schematics.
4. Purchase the optimized actual component values and construct the crossover per the schematics.

Crossover Definition

For Even Order Crossovers :
Type 1 = Linkwitz-Riley
Type 2 = Bessel
Type 3 = BEC
Type 4 = Butterworth

Low Pass Filter

$$f_{LP} := 200 \cdot \text{Hz}$$

$$LP_{order} := 2$$

$$LP_{type} := 1$$

High Pass Filter

$$f_{HP} := 500 \cdot \text{Hz}$$

$$HP_{order} := 2$$

$$HP_{type} := 2$$

(Filter Frequency)

(Filter Order : 0, 1, 2, 3, or 4)

(Filter Type : 1, 2, 3, or 4 for even order only,
for odd order this entry is ignored)

Crossover Phase Connection

$$LP_{phase} := 1$$

$$HP_{phase} := 1$$

(Phase : 1 = in phase, -1 = out of phase)

Crossover Definition - 1st Order High and Low Pass



Schematic

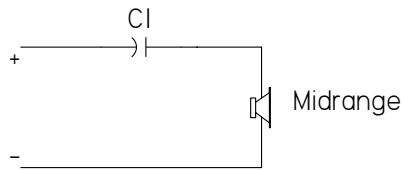

Theoretical Values

$$C_1 = 42.726 \mu\text{F}$$

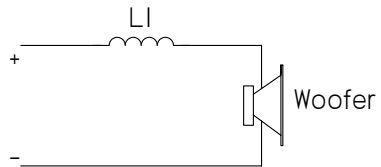

$$L_1 = 4.679 \text{ mH}$$

Enter Actual Component Values Below

High Pass

$$C_1 := 40 \cdot \mu\text{F}$$

Low Pass

$$L_1 := 4.5 \cdot \text{mH} \quad R_1 := 0.3 \cdot \Omega$$



Crossover Definition - 2nd Order High and Low Pass



Schematic

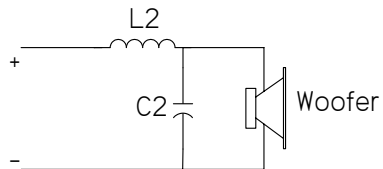
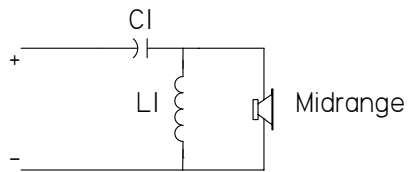

Theoretical Values

$$C_1 = 24.653 \mu\text{F}$$

$$L_1 = 4.11 \text{ mH}$$

$$L_2 = 9.358 \text{ mH}$$

$$C_2 = 67.668 \mu\text{F}$$

Enter Actual Component Values Below

High Pass

$$C_1 := 25 \cdot \mu\text{F}$$

$$L_1 := 4 \cdot \text{mH} \quad R_1 := 0.3 \cdot \Omega$$

Low Pass

$$L_2 := 10 \cdot \text{mH} \quad R_2 := 0.5 \cdot \Omega$$

$$C_2 := 68 \cdot \mu\text{F}$$



Crossover Definition - 3rd Order High and Low Pass



Schematic

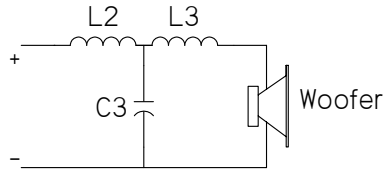
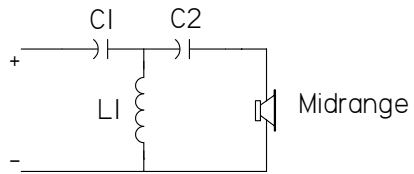

Theoretical Values

$$C_1 = 28.484 \mu\text{F}$$

$$L_1 = 1.779 \text{ mH}$$

$$C_2 = 85.452 \mu\text{F}$$

$$L_2 = 7.019 \text{ mH}$$

$$C_3 = 180.448 \mu\text{F}$$

$$L_3 = 2.34 \text{ mH}$$

Enter Actual Component Values Below

High Pass

$$C_1 := 28 \cdot \mu\text{F}$$

$$L_1 := 1.75 \cdot \text{mH} \quad R_1 := 0.2 \cdot \Omega$$

$$C_2 := 85 \cdot \mu\text{F}$$

Low Pass

$$L_2 := 7 \cdot \text{mH} \quad R_2 := 0.5 \cdot \Omega$$

$$C_3 := 180 \cdot \mu\text{F}$$

$$L_3 := 2.5 \cdot \text{mH} \quad R_3 := 0.2 \cdot \Omega$$



Crossover Definition - 4th Order High and Low Pass



Schematic

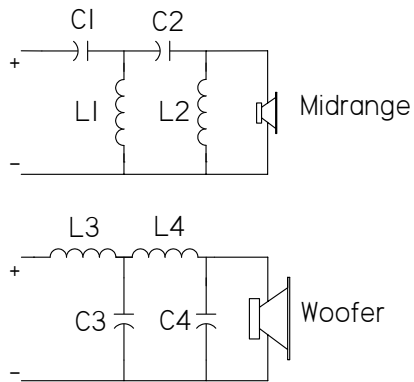

Theoretical Values

$$C_1 = 24.671 \mu\text{F}$$

$$L_1 = 1.503 \text{ mH}$$

$$C_2 = 42.738 \mu\text{F}$$

$$L_2 = 6.479 \text{ mH}$$

$$L_3 = 8.82 \text{ mH}$$

$$C_3 = 215.391 \mu\text{F}$$

$$L_4 = 4.41 \text{ mH}$$

$$C_4 = 47.874 \mu\text{F}$$

Enter Actual Component Values Below

High Pass

$$C_1 := 25 \cdot \mu\text{F}$$

$$L_1 := 1.5 \cdot \text{mH} \quad R_1 := 0.1 \cdot \Omega$$

$$C_2 := 43 \cdot \mu\text{F}$$

$$L_2 := 6.5 \cdot \text{mH} \quad R_2 := 0.3 \cdot \Omega$$

Low Pass

$$L_3 := 9 \cdot \text{mH} \quad R_3 := 0.5 \cdot \Omega$$

$$C_3 := 215 \cdot \mu\text{F}$$

$$L_4 := 4.5 \cdot \text{mH} \quad R_4 := 0.3 \cdot \Omega$$

$$C_4 := 48 \cdot \mu\text{F}$$



End of Detailed Input

End of Part 1 Input

OB Driver Impedance

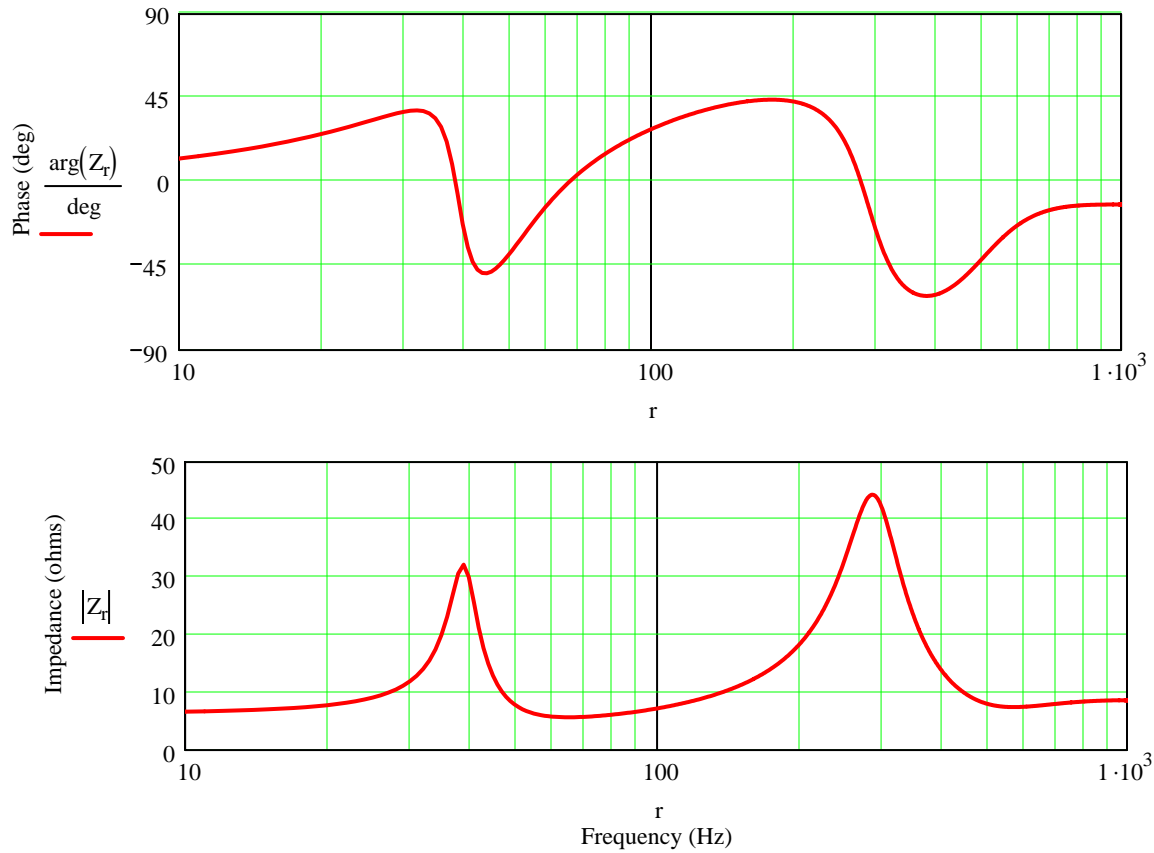

Driver RMS Displacements (Red Curve - Woofers, Blue Curve - Extended Range Driver)

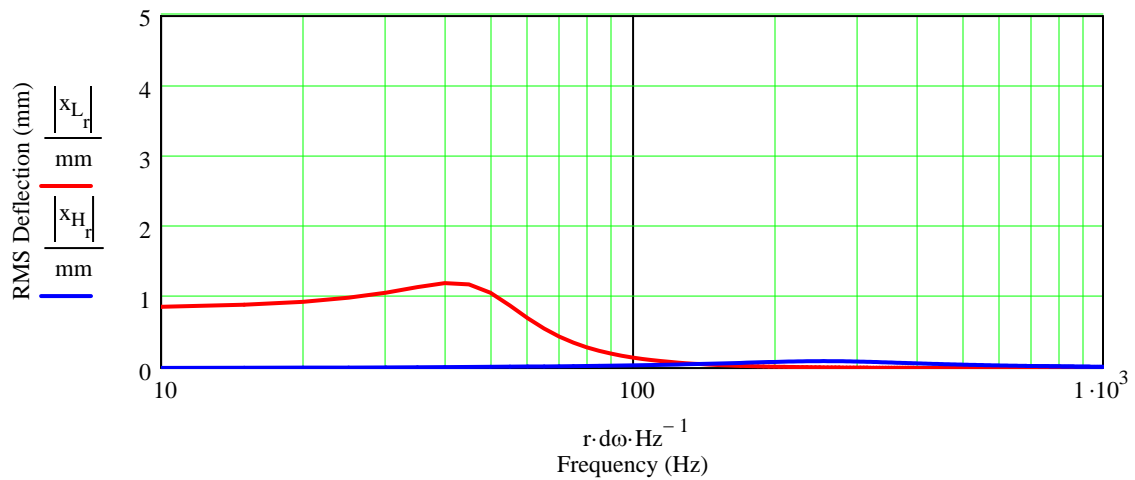

Part 2 : Detailed SPL Response Calculation

Calculation Includes :

- Position of Drivers on the Baffle.
- Open Baffle Defraction for the Drivers.
- Floor Reflection for the Drivers.

Geometry

Coordinate System :

- Origin is the lower left corner of the front baffle
- y = horizontal direction
- z = vertical direction

The variables num_r, n_low, and n_high control the number of simple sources used in the calculations. Increasing each will improve accuracy at the expense of longer calculation times. Increase each variable until final plotted SPL stops changing at which point the solution has converged.

Enclosure Geometry Input

- $X_0 := 2\text{-ft}$ (Front Baffle Distance from Rear Wall > Depth of Enclosure)
- $Y_0 := 1.5\text{-ft}$ (Front Baffle Distance from Side Wall)
- $\theta_0 := 45\text{-deg}$ (Rotation Towards Room Center)
- $Z_0 := 8\text{-ft}$ (Floor to Ceiling Distance)
- stand := 0·m (Height from Floor to Bottom Edge of Front Baffle)
- num_r := 10 (Number of Points per Unit Length of Baffle Edge)

Corner Coordinates

- | Y coordinate | Z coordinate | |
|---------------------------|---------------------------|-----------------------|
| $y_{o_0} := 20\text{-in}$ | | (Bottom Right Corner) |
| $y_{o_1} := 20\text{-in}$ | $z_{o_1} := 38\text{-in}$ | (Top Right Corner) |
| $y_{o_2} := 0\text{-in}$ | $z_{o_2} := 38\text{-in}$ | (Top Left Corner) |
| $y_{o_3} := 0\text{-in}$ | | (Bottom Left Corner) |

Extended Range Driver Geometry Input

- $y_{dc} := 8\text{-in}$ (Driver Center y Coordinate)
- $z_{dc} := 32\text{-in}$ (Driver Center z Coordinate)
- n_high := 4 (Number of Points Across Diameter)

Woofers Driver Geometry Input

- $y_{w1} := 10\text{-in}$ (Lower Driver Center y Coordinate)
- $z_{w1} := 10\text{-in}$ (Lower Driver Center z Coordinate)
- n_low := 10 (Number of Points Across Diameter)

Listening Position (Default Location is at 1 m Distance Along the Driver's Axis)

$n_listen = 0$ (Listening Position Relative to Speaker)
 $radius := 1 \cdot m$ (Calculation Radius, Effective Radius is Greater if y_p is Changed from Default)
 $\theta := 0 \cdot deg$ (0 deg is along the Driver's Axis, $-80 \text{ deg} < \theta < 80 \text{ deg}$)
 $z_p := z_{dc}$ (Default Height is Equal to Driver Height)

$n_listen = 1$ (Listening Position Relative to the Room Corner)
 $X_p := 10ft$
 $Y_p := 7 \cdot ft$
 $Z_p := z_{dc} + stand$ (Default Height is Equal to Driver Height)
 $n_listen := 0$ (Method Selection)

Floor Condition

$Reflect := 1$ (0 = hardwood or concrete, 1 = carpeted)

Reflective Surface Selections (if 1 reflective surface is included, if 0 reflective surface is removed)

$Inc_floor := 1$ (Floor, $Z = 0$)
 $Inc_rear := 0$ (Rear Wall, $X = 0$)
 $Inc_side := 0$ (Left Side Wall, $Y = 0$)
 $Inc_ceiling := 0$ (Ceiling)



Extended Range Driver and Woofer : Simple Source Pattern with Baffle Edge Outline

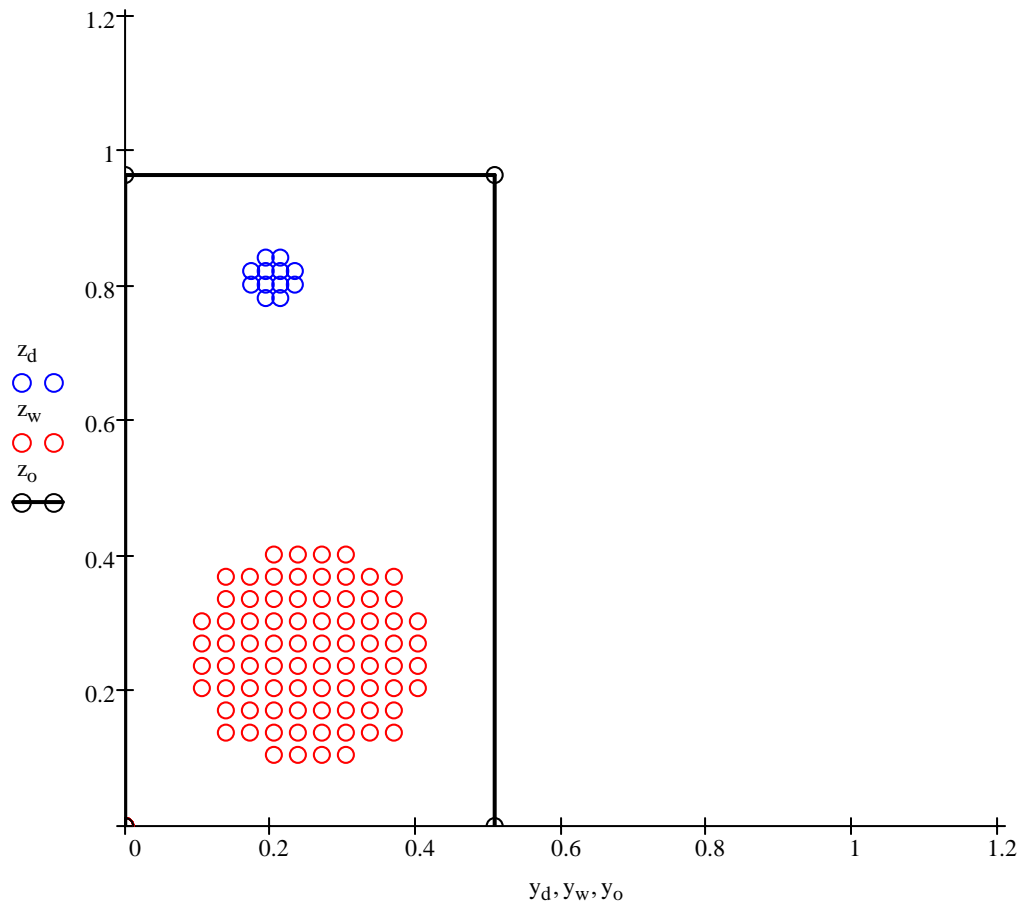



Three Dimensional View

Axis Length (m) axis := 2 <---- Change value of "axis" to rescale plots

Room Corner is the Origin

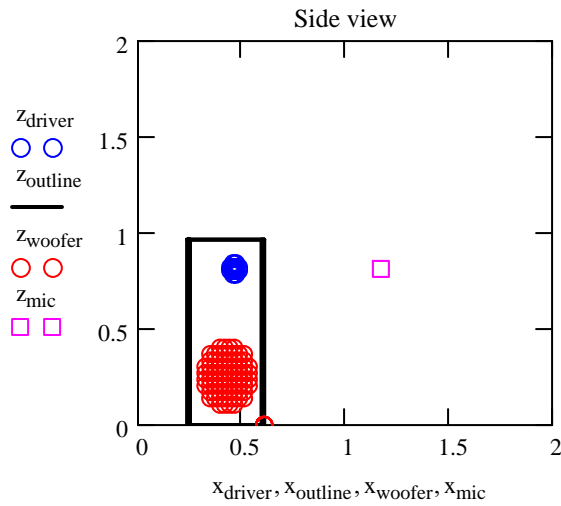

Side View - looking out from side wall

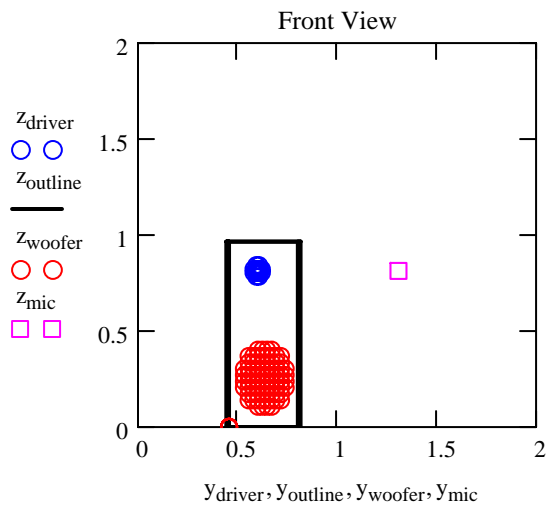

Front View - looking towards rear wall

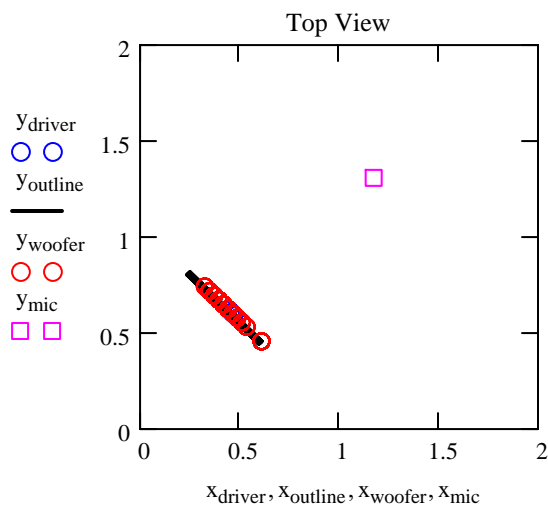

Top View - looking down from ceiling



Plotted Response for the Extended Range Driver

Dashed Red - Infinite Baffle Response

Dashed Magenta - Baffle Response

Dashed Brown - Crossover Response

Solid Red - Combined Response

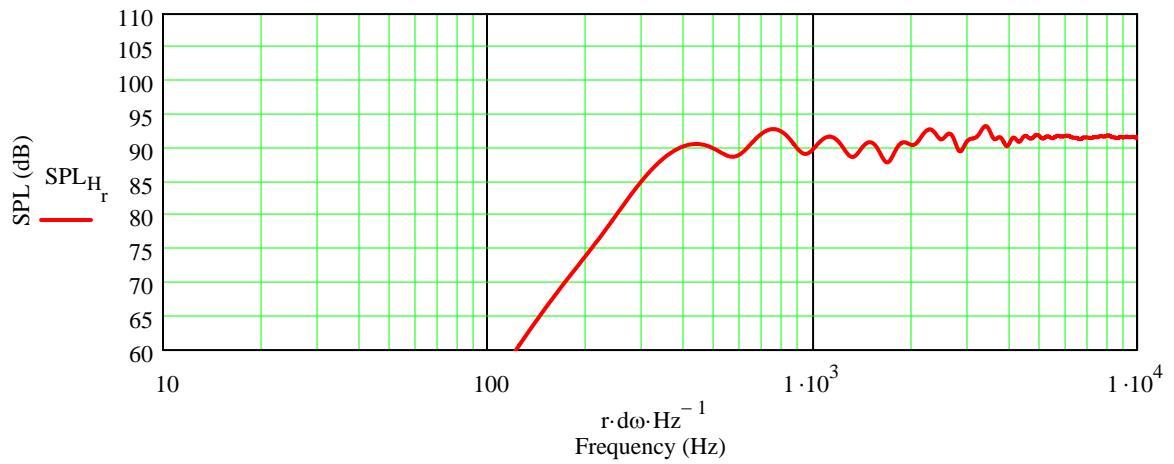
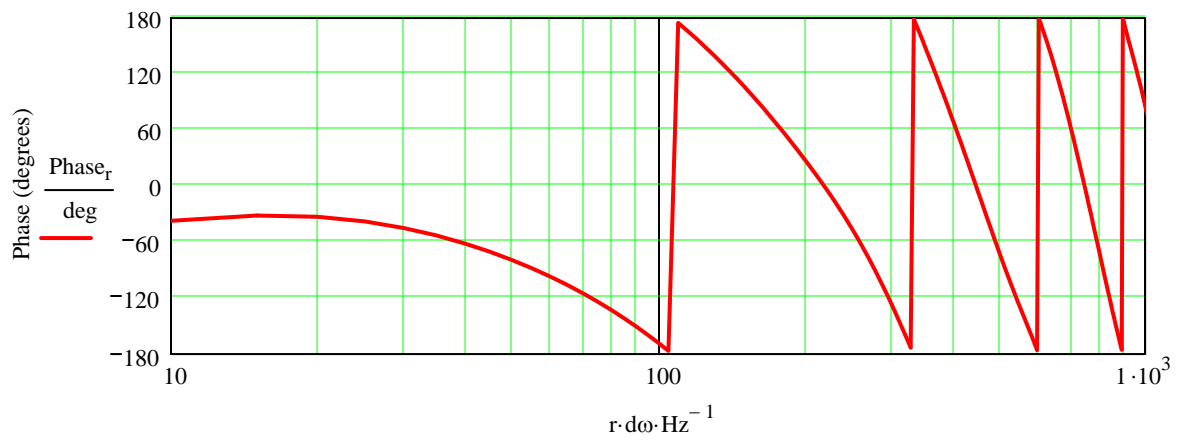
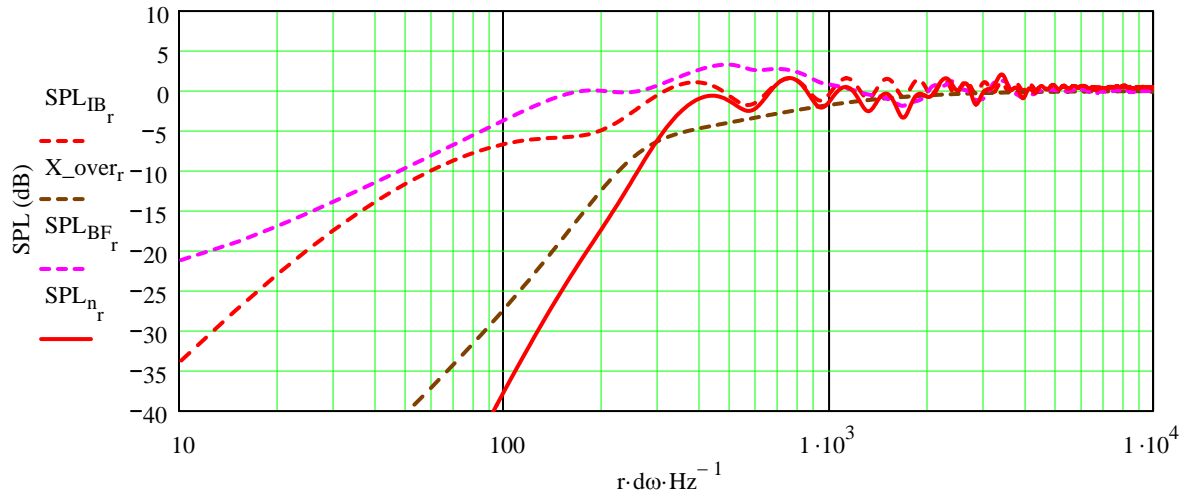

Plotted Response for the Woofer Driver

Dashed Red - Infinite Baffle Response
 Dashed Magenta - Baffle Response
 Dashed Brown - Crossover Response
 Solid Red - Combined Response

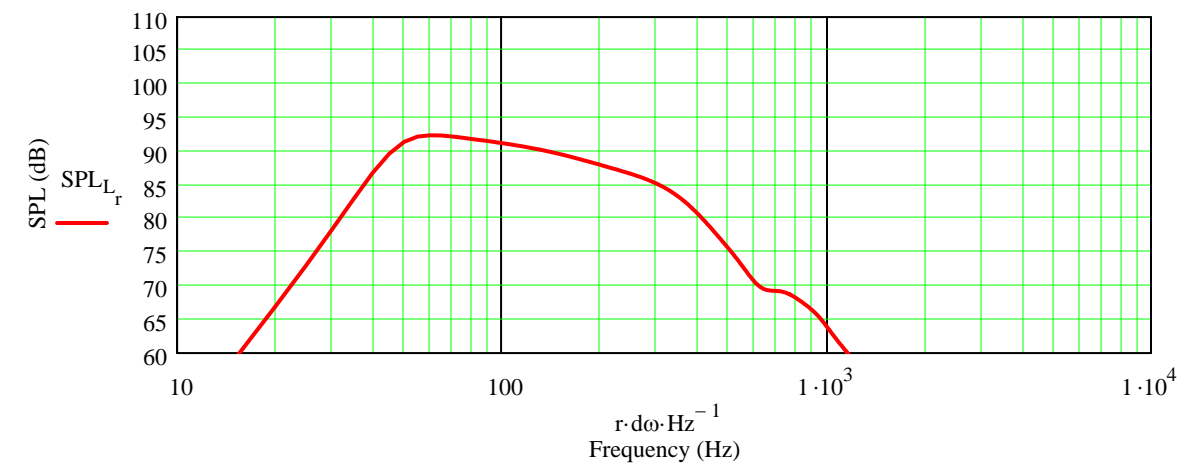
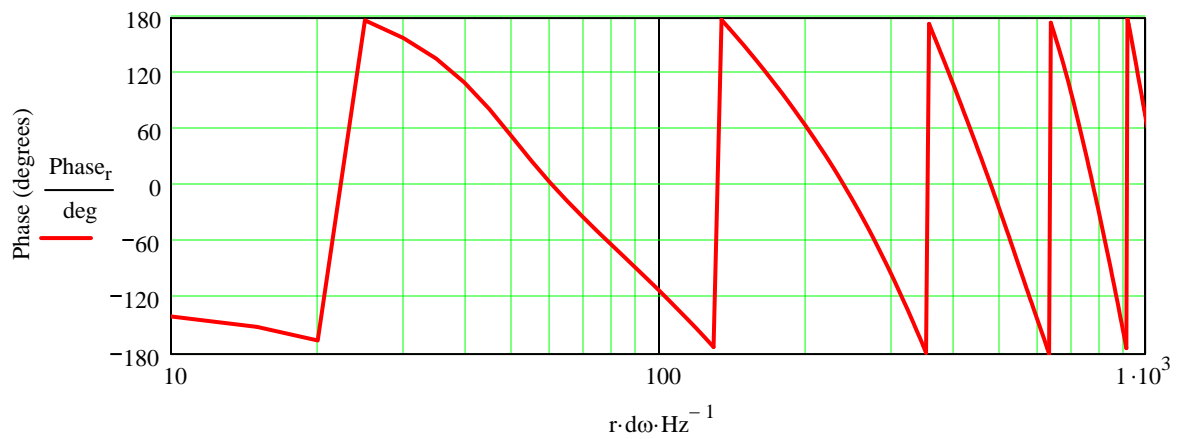
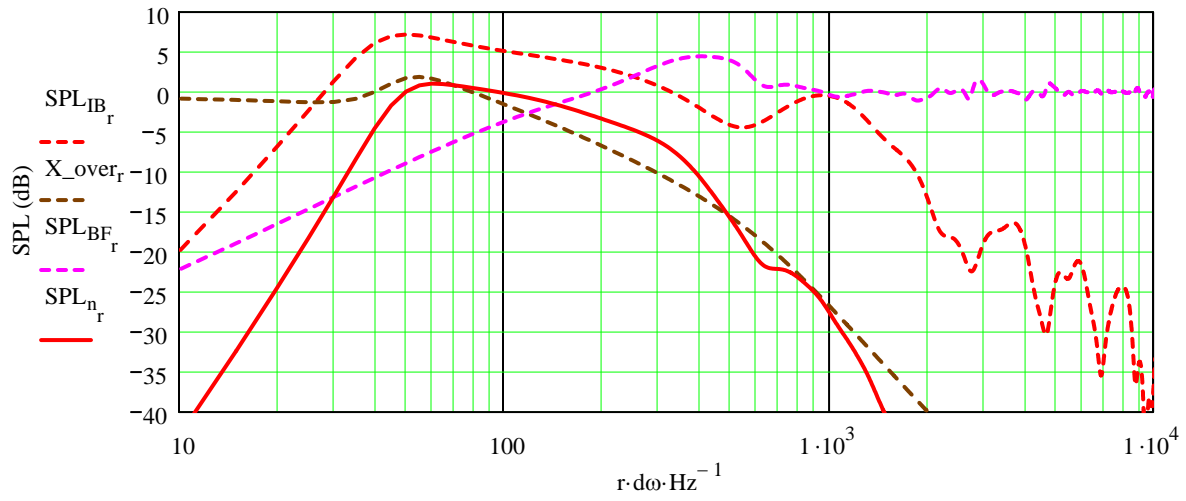

Plotted System Response for the Extended Range and Woofer Open Baffle Design

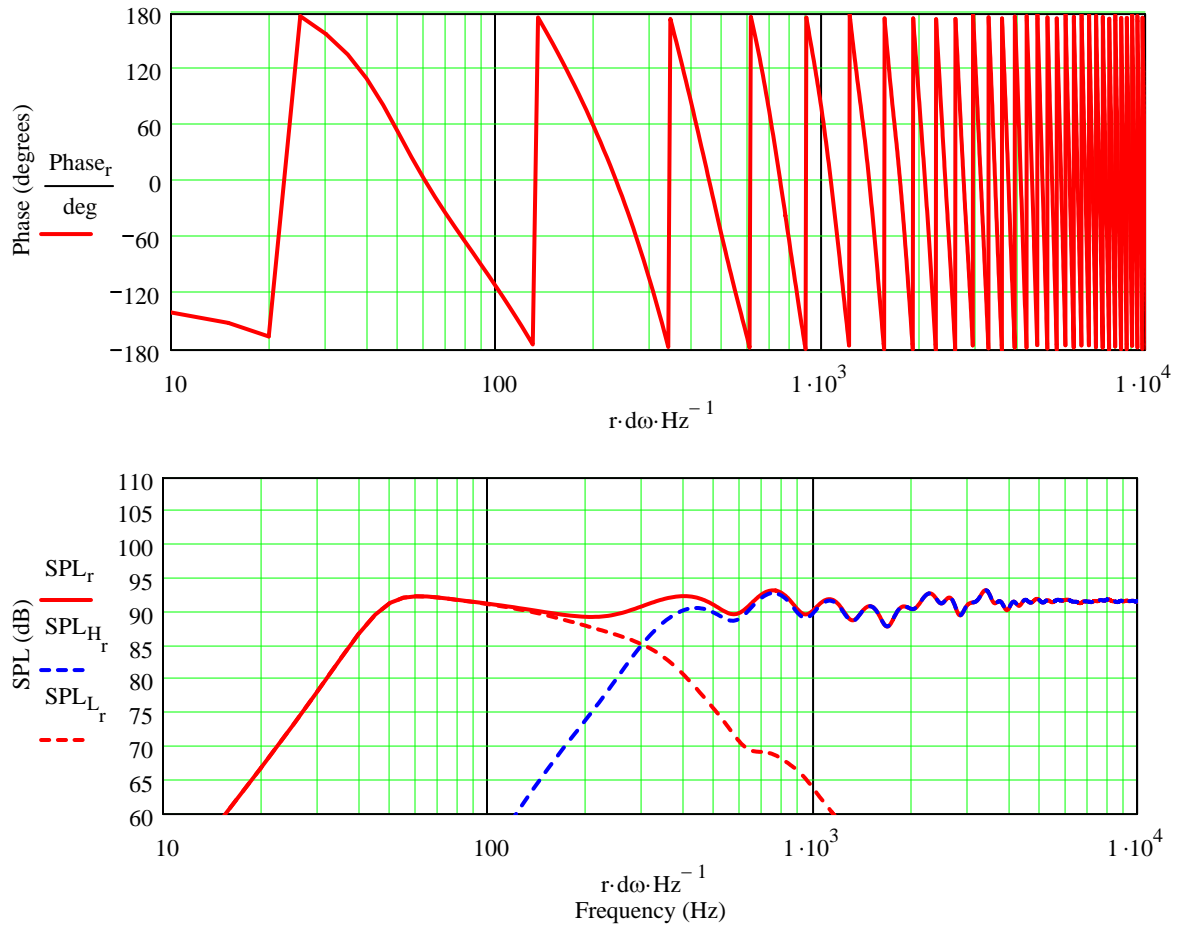

System Time Response for an Impulse Input

